

## CLOW LONG-SPAN PIPE

Mechanical Joint with O-Ring Rubber Gasket Flanged Joint For Elevated Pipe Lines to Reduce Costs of Piers

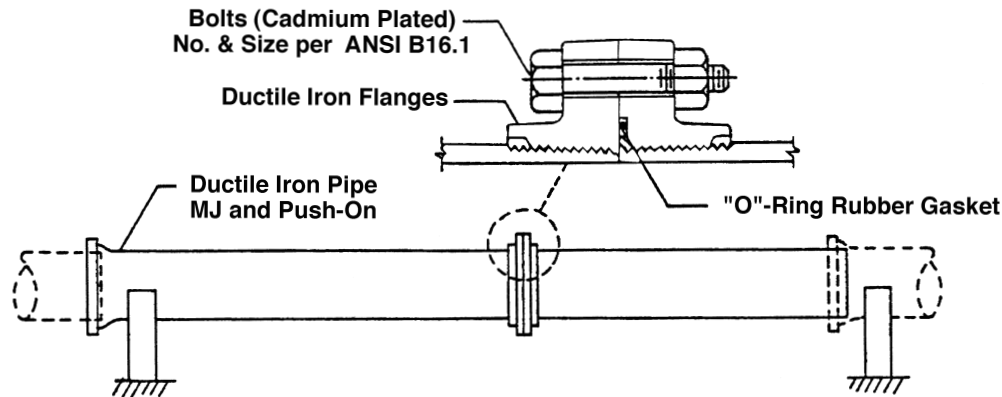

**Section of O-Ring Flanged Joint**

### Mechanical Joint or Push-on & Flanged Long-Span Pipe

Long-Span Pipe is a ductile cast iron multiple length pipe utilizing a special Clow-designed O-Ring Rubber Gasket Joint for the purpose of minimizing the number of piers required in elevated lines. 27-foot units are 18-foot lengths of MJ and Flanged, plus 9-foot lengths of Flanged and Plain End. 36-foot units are 18-foot lengths of MJ & Flanged and 18-foot lengths of Flanged & Plain End. 45-foot units are 18-foot Mechanical Joint & Flanged, 17-foot Flanged & Flanged, and 10-foot Flanged & Plain End pieces.

Installation requires support under each MJ bell, with allowance for expansion and contraction. Length tolerance of each unit is plus or minus 1/4-inch.

Pipe are shipped unassembled, with accessories packaged separately. Pipe conforms to ANSI A21.51.

Flanges are 70-50-05 ductile iron using cadmium-plated bolts of the same size and number as ANSI B16.1 125 pound flanges.

## DIMENSIONS AND WEIGHTS

Nominal Pipe Size (Inches)	Pressure Rating (psi)	Unit Laying Length (Feet*)	Wall Thickness		Deflection † at Center of Span (Inches)	Weight—Pounds
			A21.51 Class	In Inches		Per Unit Total Length Empty Pipe Including Accessories
6	250	27	54	.37	.53	690
8	250	27	54	.39	.34	965
10	250	27	54	.41	.24	1260
12	250	36	54	.43	.57	2080
14	250	36	54	.45	.45	2545
16	250	36	54	.46	.37	2990
18	250	36	55	.50	.29	3615
18	250	45	56	.53	.70	4890
20	250	36	55	.51	.25	4130
20	250	45	56	.54	.60	5595
24	250	36	56	.56	.18	5450
24	250	45	56	.56	.45	7045
30**	250	36	55	.59	.13	7210
30**	250	45	55	.59	.32	9395

\* Plus or minus 1/4 inch.

† With pipe full of water.

\*\*30" size is furnished FastTite only. Other sizes are normally furnished with Mechanical Joint but can also be furnished Tyton Joint.

Note: Unit laying lengths shorter than those listed above can also be furnished.